



ERM1600 (1600 KW) MITSUBISHI DIESEL GENERATOR SET

	STAND-BY	PRIME
ERM1600 RATED OUTPUT	60 HZ	
GENERATOR OUTPUT (KW)	1600	1440
GENERATOR OUTPUT (KVA)	2000	1800
ENGINE SPEED (RPM)	1800	1800

FUEL CONSUMPTION AT LOAD (PERCENT OF RATED OUTPUT)	100%	75%	50%
1600 KW of Power—Fuel (GPH)	126.2	93.8	64.8

HZ	WIRE	VOLTAGE RANGE	
60 HZ	3	416 — 480	208 — 240
60 HZ	4	240/416 — 277/480	120/208 — 138/240

NOTE: 4160 & 13800 are also available.

WEIGHT / DIMENSIONS WITH RADIATOR (INDOOR UNIT ONLY)	
W x L x H (in)	94" x 236" x 130"
Wet Weight (lb)	32,250

The **ERM1600 (1600 kW)** stand-by or prime generation system stands out as a leader in its class with a Standby output of **1600 kW** and a Prime output of **1440 kW**. It is powered by a heavy duty **MITSUBISHI** engine and coupled with an efficient Stamford generator. This ENER-G Rudox generator set will meet and exceed all your power generation needs. At **126.2 GPH** at full load, the fuel efficiency of the reliable **MITSUBISHI** engine provides the consistent, dependable performance you have come to expect from any ENER-G Rudox product. The unit is loaded with standard equipment such as a Digital Controller and the customer control interface is easy to operate with basic displays such as voltage, current and fuel level as well as alarms like over voltage, low oil pressure and high coolant temperature. All of this comes with the exceptional 24 hour, seven day a week service guarantee provided by the ENER-G Rudox professional service team.

PERFORMANCE CHARACTERISTICS

Standard ENER-G Rudox Generator Sets have High Performance Components to meet the Toughest Applications.

- ▶ **FAST STARTING**
Load Transferred in 5-10 Seconds depending on Starting Accessories
- ▶ **PARALLELING OPTIONS**
Controls can be added for completely Automatic Multi-Unit Synchronization and Load Sharing
- ▶ **HIGH MOTOR STARTING CAPACITY**
250% of Rated Capacity for 10 Seconds

Fast Recovery on Sudden Application of Full Load (3 - 6 Seconds Typical)
- ▶ **PERMANENT MAGNET EXCITATION**
Provides Excellent Performance with Heavy SCR Loads

300% Full Load Current Available for 10 Seconds During Short Circuit Condition
- ▶ **PRECISE VOLTAGE REGULATION**
± ½ % Steady State
± 1 % from No Load to Full Load
- ▶ **PRECISE FREQUENCY CONTROL**
The Woodward ProAct Isochronous Governor has 0% Droop, No Load to Full Load, and ± 1/4 % Steady State
- ▶ **UL2200**
Units are built to U.L. Standards; U.L. Certificate is also available

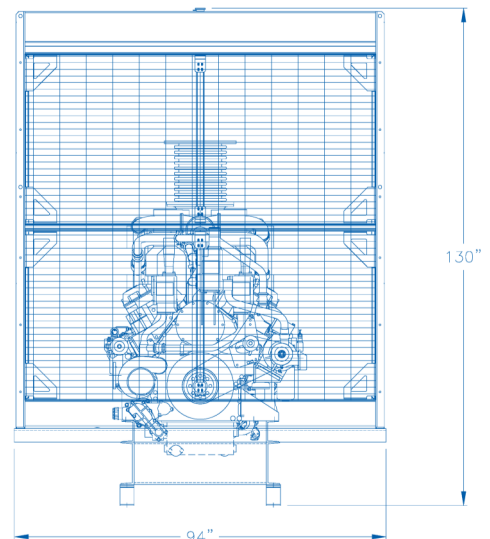
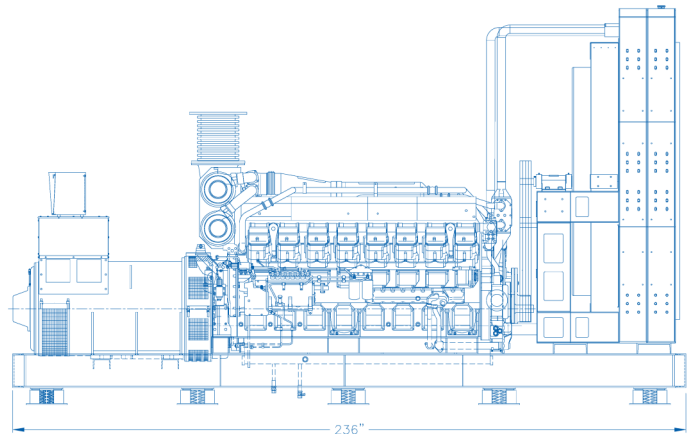

ENER-G Rudox 1600kW Diesel Standby Generator - ERM1600-170525

GENERATOR SET SPECIFICATIONS

	STAND-BY	PRIME
ERM1600 RATED OUTPUT	60 HZ	
ENGINE SPEED (RPM)	1800	1800
ENGINE H.P. (GROSS HP)	2346	2133
GENERATOR OUTPUT (KW)	1600	1440
GENERATOR OUTPUT (KVA)	2000	1800
COOLING AIR FLOW (ACFM)	100548	100548
COMBUSTION AIR FLOW (SCFM)	5932	5332
EXHAUST GAS FLOW (ACFM)	15642	14089
HEAT REJECTION TO AMBIENT (BTU/MIN)	12073	10640

STANDARD EQUIPMENT

- ▶ Mitsubishi S16R-Y2PTAW-1 Four Cycle Tier II Diesel Engine rated for USA EPA Tier II Emissions for Stand-By Use
- ▶ Newage Stamford Generator (PI734D) with (MX321) Static Voltage Regulator and Permanent Magnetic Excitation rated per NEMA Code at 150°C (480 VAC)
- ▶ Heavy Duty Structural Steel Sub-Base
- ▶ Mitsubishi PS8 Type Fuel System with Woodward ProAct Controller for Isochronous Speed (0% droop)
- ▶ Unit Mounted Radiator for 104°C Ambient and 0.5" Additional Static
- ▶ 24 Volt Electric Start System with Battery Charging Alternator
- ▶ Residential Silencer with Stainless Steel Flexible Connection
- ▶ 24 Volt Lead Acid Batteries, Rack and Cables
- ▶ Flexible Fuel Lines
- ▶ Unit Mounted Control Panel with Digital Controller

OPTIONAL EQUIPMENT

Critical Silencer	Remote Annunciator	Battery Charger
Heat Exchanger Cooling	High Ambient Radiator	Extreme Dust Air Cleaner
Outdoor Sound Attenuated Enclosure	Load Bank	High Voltage Generator 4160 or 13800
Day Tank	Vibration Dampers	Remote Communications
Automatic Transfer Switch	Paralleling Controls	U.L. Certifications
Mainline Circuit Breaker	Low Temperature Rise Generator	Others, as Required
		NFPA-110 Compliant

DIESEL ENGINE – MITSUBISHI S16R-Y2PTAW-1 TIER II

TYPE	4 Cycle, Water-Cooled, Turbo Charged, Intercooled
COMBUSTION CHAMBER	Direct Injection
CYLINDER ARRANGEMENT	60° V, 16 Cylinder
DISPLACEMENT	3989 Cubic Inch
EXHAUST FLEX DIAMETER	14 Inches (inside)
MUFFLER DIAMETER	16 Inches (Inside)
MAXIMUM ALLOWABLE BACK PRESSURE	23.6 Inches H ₂ O
FUEL SUCTION SIZE MAX FLOW (GPM)	1 Inch NPT; 2.46 GPM
FUEL RETURN SIZE MAX FLOW (GPM)	1 Inch NPT; 1.0 GPM



DISPLAYS FOR DIGITAL CONTRAL PANEL

Engine Speed	L-L & L-N Voltage	Frequency
Hours Run	Current (Amps) per Phase	Power Factor
Fuel Level	kW per Phase & Total	Gen V & I Unbalance
Battery Voltage	kVA per Phase & Total	Various Others

ENGINE / GENERATOR ALARMS

Low Fuel Level	High Coolant Temperature	Reverse Power
Low Coolant Level	Emergency Stop	Excitation Loss
Low Oil Pressure	Over and Under Voltage	Overcurrent
Over-speed	Over and Under Frequency	Various Others



ENER-G Rudox, founded in NJ in 1949, is a full service energy product provider for commercial and industrial energy applications. Products include energy efficient Stand-by Power Solutions, Emergency Rentals, Cogeneration, and CHP or CCHP/Tri-Generation systems with state of the art monitoring capabilities. ENER-G Rudox can recommend different techniques and Holistic technologies and can develop, deliver and finance sustainable energy solutions. In-house capabilities allow ENER-G Rudox to design and supply a system to meet the customer's exact specifications. With its fully staffed 24/7 Service Department and Parts Department, ENER-G Rudox has established a reputation of providing quality machines with responsive, reliable, personalized service at competitive prices.

All information detailed is for guidance only and is subject to change without notice due to our commitment to continuous improvement. All values should be confirmed with ENER-G Rudox (ER) on a project specific basis.